

# BRAKE PARTS

*for Calipers, Disc & Drum Brakes*

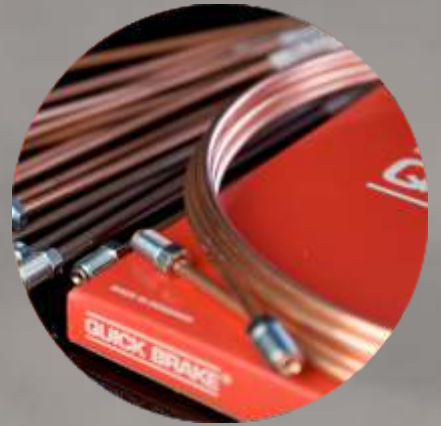

**QUICK BRAKE<sup>®</sup>**



# **OJD** Automotive

**The Brake Accessory specialist from Denmark**

OJD Automotive was founded in 1971, which means that we have more than 50 years of experience in Brake Accessories. With our extensive product range QUICK BRAKE, we cover more than 90% of the European and Asian vehicle types.

Through constant development our product lines are updated accordingly to requests in the market.

**Our Product Range includes:**

- **Brake Lines (Copper, Copper-Nickel and Steel)**
- **Brake Components (Screws, Fittings, Bolts etc.)**
- **Brake Accessory Kits**
- **Brake Hoses**
- **Brake Wear Sensors**

Our extensive knowledge base, built up since 1971, enable us to be dynamic, creative and competent. We are able to professionally guide our customer in the purchase of our complete product line. On the basis of good business acumen, trust and knowledge.

OJD Automotive ApS is certified according to the quality standard system ISO 9001 and ISO 14001. Furthermore, we are approved supplier to main brake system and Brake Pad/Shoe manufacturers.

---

**QUICK BRAKE**®

---

# Brake Lines

## Copper, Copper-Nickel and Steel

ABE release  
for CUNI Brake Lines  
KBA No. 61429



Ref.	Description
CU-FO568	Brake line set for Ford
CU-BM161	Brake line set for BMW
CU-PE038	Brake line set for Peugeot
CU-PE046	Brake line set for Peugeot
CU-HY015	Brake line set for Hyundai
CU-PE039	Brake line set for Peugeot
CU-OP025	Brake line set for Opel
CU-SZ020	Brake line set for Suzuki
CU-KI010	Brake line set for KIA
CU-BM154	Brake line set for BMW
CU-OP310	Brake line set for Opel
CU-BM214	Brake line set for BMW
CU-VW324	Brake line set for VW
CU-SK011	Brake line set for Skoda
CU-PE162	Brake line set for Peugeot
CU-VW268	Brake line set for VW
CU-OP354	Brake line set for Opel
CU-CI725	Brake line set for Citroën
CU-BM152	Brake line set for BMW
CU-VW619	Brake line set for VW

### Brake Line Sets

All Brake Lines required for a specific car model. The Brake Lines are ready to fit, in correct lengths with flarings and fittings.

All is supplied in one box with application details. A complete set ensures a complete maintenance of the brake line system.

Ref.	Description
CU-0200A-A	Loose Brake Line with fittings
CU-0700A-A	Loose Brake Line with fittings
CU-0300A-A	Loose Brake Line with fittings
CU-0650A-A	Loose Brake Line with fittings
CU-0510A-A	Loose Brake Line with fittings
CU-0800A-A	Loose Brake Line with fittings
CU-0100A-A	Loose Brake Line with fittings
CU-0500A-A	Loose Brake Line with fittings
CU-0150A-A	Loose Brake Line with fittings
CU-0400A-A	Loose Brake Line with fittings
CU-0610A-A	Loose Brake Line with fittings
CU-0260A-A	Loose Brake Line with fittings
CU-0360A-A	Loose Brake Line with fittings
CU-0480A-A	Loose Brake Line with fittings

### Brake Lines

The individual Brake Lines are ready to fit. Correct length, flaring and fittings are pre-made, enabling the mechanic to do a specific repair.

Furthermore you can find our brake lines in TecDoc linked to vehicles.

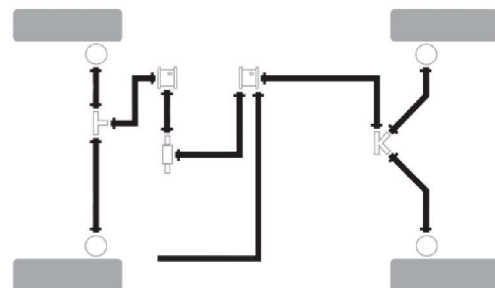

All application data can be found in TecDoc



# Brake Lines

Copper, Copper-Nickel and Steel

ABE release  
for CUNI Brake Lines  
KBA No. 61429



**Copper**

Ref.	Diameter	Length
1910 CU	3/16"	7,62 m
1910R CU-5M	3/16"	5 m
1911R CU-10M	3/16"	10 m
1911R CU-25M	3/16"	25 m
1911 CU RING	3/16"	50 m
1912 CU-159M	3/16"	159 m
1920 CU	1/4"	7,62 m
1922 CU RING	1/4"	100 m
1930 CU	5/16"	7,62 m
1940 CU	3/8"	7,62 m
1950 CU	5 mm	5 m
1951 CU RING	5 mm	50 m
1952 CU RING	5 mm	134 m
1960 CU	6 mm	5 m
1961 CU-10M	6 mm	10 m
1962 CU RING	6 mm	107 m
1970 CU	8 mm	5 m
1971 CU-10M	8 mm	10 m
1980 CU	10 mm	5 m
1982 CU RING	10 mm	60 m



**Copper-Nickel**

Ref.	Diameter	Length
1915 CUNI	3/16"	5 m
1917 CUNI RING	3/16"	10 m
1916 CUNI RING	3/16"	25 m
1925 CUNI	1/4"	5 m
1935 CUNI	5/16"	5 m
1965 CUNI	6 mm	5 m
1967 CUNI RING	6 mm	10 m



**Steel**

Ref.	Diameter	Length
0181 ST RING	3/16"	5 m
0186 ST RING	6 mm	5 m

The Brake Lines are supplied in small or large coils with no flarings or fittings. The mechanics cut into the requested length and produce the flaring and mount the correct fittings.

In order to secure a safe braking, the Brake Lines play an important part and should be inspected during every brake check. The benefits of changing the Brake Lines are:

- Increased safety for the customers.
- Ready to fit lines and sets reduce brake repair time.
- Complete brake repair.
- Reputation as a brake specialist.

For further information please check at your local wholesaler.



# Workshop Kit

## Ref. 0001



### Fittings for Brake Lines

Ref.	d1	d2	s x tl	Pcs.
A	M10 x 1	ø5,2	11 x 16,7	20
B	M12 x 1	ø6,2	12 x 18	5
B5.0	M12 x 1	ø5,2	12 x 20	5
E	M10 x 1	ø5,2	14 x 14	5
F	3/8" x 24 UNF	ø5,2	11 x 21	20
H	3/8" x 24 UNF	ø5,2	14 x 17,5	5
J	3/8" x 24 UNF	ø5,2	10 x 14,4	5
KX	3/8" x 24 UNF	ø5,2	12 x 16	5
L	M10 x 1,25	ø5,2	10 x 19,5	10
M	M10 x 1,25	ø5,2	10 x 14,2	10
S	3/8" x 24 UNF	ø5,2	10 x 18	10
TX	M10 x 1	ø5,2	10 x 18	10
<b>Total</b>				<b>110</b>



## Ref. 0001A



### Fittings and Connectors for Brake Lines

Ref.	d1	d2	s x tl	Pcs.
BX	M12 x 1	ø6,5	12 x 18	5
C	M10 x 1	ø5,2	11 x 24,8	5
EV	M10 x 1	ø5,2	14 x 15	5
OAA	M10 x 1	ø3,5	14 x 24	5
OBB	M12 x 1	ø4,5	17 x 29	2
OFF	3/8" x 24 UNF	ø3,1	14 x 33,2	2
OKK	3/8" x 24 UNF	ø3,2	11 x 28	2
PA	7/16" x 24 UNF	ø6,5	12 x 15,5	2
PF	1/2" x 20 UNF	ø5,2	13 x 18	2
PG	7/16" x 20 UNF	ø5,2	12 x 21,5	5
T	M10 x 1	ø5,2	10 x 18	5
X	For one 3/16" or 5 mm line			5
<b>Total</b>				<b>45</b>

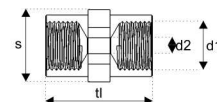
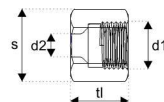
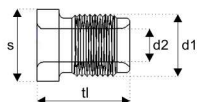

# Workshop Kit

## Ref. 0001B

Fittings for Brake Lines

Ref.	d1	d2	s x tl	Pcs.
A	M10 x 1	ø5,2	11 x 16,7	10
B	M12 x 1	ø6,2	12 x 18	5
B5.0	M12 x 1	ø5,2	12 x 20	5
BX	M12 x 1	ø6,5	12 x 18	4
C	M10 x 1	ø5,2	11 x 24,8	4
D	M10 x 1	ø5,2	10 x 16,7	5
E	M10 x 1	ø5,2	14 x 14	5
EV	M10 x 1	ø5,2	14 x 15	4
F	3/8" x 24 UNF	ø5,2	11 x 21	5
H	3/8" x 24 UNF	ø5,2	14 x 17,5	4
J	3/8" x 24 UNF	ø5,2	10 x 14,4	4
KX	3/8" x 24 UNF	ø5,2	12 x 16	4
L	M10 x 1,25	ø5,2	10 x 19,5	5
M	M10 x 1,25	ø5,2	10 x 14,2	4
PF	1/2" x 20 UNF	ø5,2	13 x 18	4
S	3/8" x 24 UNF	ø5,2	10 x 18	5
T	M10 x 1	ø5,2	10 x 18	4
TX	M10 x 1	ø5,2	10 x 18	10
<b>Total</b>				<b>91</b>



## Ref. 0001C

Connectors for Brake Lines

Ref.	d1	d2	s x tl	Pcs.
OAA	M10 x 1	ø3,5	14 x 24	2
OBB	M12 x 1	ø4,5	17 x 29	2
ODD	M10 x 1	ø3,5	14 x 24	2
OEE	M10 x 1	ø3,2	11 x 28	2
OFF	3/8" x 24 UNF	ø3,1	14 x 33,2	2
OKK	3/8" x 24 UNF	ø3,2	11 x 28	2
O3A	M10 x 1	ø3	-	1
O3B	M12 x 1	ø3,5	-	1
OAE	M10 x 1	ø3,2	14 x 29	2
OBE	M12 x 1	ø3,2	15 x 32	2
STT	Connector for 3/16" lines			2
STT5.0	Connector for 5 mm lines			2
<b>Total</b>				<b>22</b>

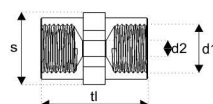
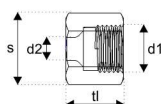
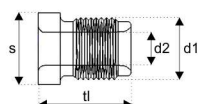

# Workshop Kit

## Ref. 0001D

### Clips & Connectors for Brake Lines

Ref.	Description	Pcs.
W	Connector for two 3/16" or 5 mm lines	4
WA	Connector for two 3/16" or 5 mm lines	4
WB	Connector for three 3/16" or 5 mm lines	4
WD	Connector for two 3/16" or 5 mm lines and two 5/16" or 8 mm lines	2
X	Connector for one 3/16" or 5 mm lines	4
XA	Connector for one 3/16" or 5 mm lines	4
XB	Connector for one 1/4" or 6 mm lines	4
XC	Connector for one 5/16" or 8 mm lines	4
STT	Connector for 3/16" lines	2
STT5.0	Connector for 5 mm lines	2
STT6.0	Connector for 6 mm lines	2
STT8.0	Connector for 8 mm lines	2
<b>Total</b>		<b>38</b>



## Ref. 0002

### Bleeder Screws

Ref.	d	s x tl	Pcs.
0010	M8 x 1,25	9 x 41,5	5
0017	M10 x 1	10 x 34	5
0033	M6 x 1	7 x 29	5
0039	M10 x 1	11 x 29,9	5
0053	M7 x 1	7 x 21,7	5
0086	M7 x 1	7 x 30,5	5
0087	M7 x 1	7 x 38,3	5
0100	M8 x 1,25	8 x 24,5	5
0107	3/8" x 24 UNF	10 x 31	5
0108	3/8" x 24 UNF	10 x 36,7	5
0120X	1/4" x 28 UNF	8 x 28	5
0125			20
<b>Total</b>			<b>75</b>

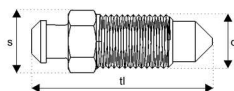



# Workshop Kit

## Ref. 0002A



### Bleeder Screws

Ref.	d	s x tl	Pcs.
0011	M8 x 1,25	9 x 35,5	5
0013	M6 x 1	7 x 38	5
0015	M8 x 1,25	9 x 32,5	5
0018	M10 x 1	10 x 36,5	5
0019	M10 x 1	11 x 36	5
0069	M7 x 1	7 x 28,6	5
0085	M8 x 1,25	9 x 49	5
0088	M7 x 1	9 x 33	5
0089	M8 x 1	8 x 32	5
0090	M8 x 1	9 x 33,5	5
0094	M7 x 1	8 x 55,5	5
0125	-	-	20
<b>Total</b>			<b>75</b>



## Ref. 0004B



### Fixing Screws for Disc and Drum Brakes

Ref.	d	s x tl	Pcs.
11660	M6 x 1	14 x 15	4
11661	M8 x 1	14 x 12,5	4
11662	M8 x 1,25	15,9 x 15,7	6
11663	M8 x 1,25	15,5 x 17	4
11664	M12 x 1,5	18,8 x 21,3	6
11665	M8 x 1,25	15,8 x 16,1	4
11666	M10 x 1,25	13,3 x 19,4	4
11667	M6 x 1	11 x 16,1	6
11668	M8 x 1,25	10,9 x 15,6	6
11669	M10 x 1,5	10 x 18,9	4
11670	M10 x 1,5	18 x 19,7	6
11671	M6 x 1	11 x 14	4
<b>Total</b>			<b>58</b>

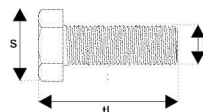
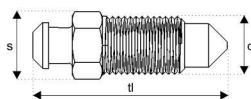

# Workshop Kit

## Ref. 0004C



Fixing Screws for Disc and Drum Brakes

Ref.	d	s x tl	Pcs.
11558X	M10 x 1,5	20 x 38,6	5
11622	M6 x 1	11,7 x 19,9	5
11667	M6 x 1	11 x 16,1	5
11671	M6 x 1	11 x 14	5
11672	M8 x 1,25	11,8 x 17,8	5
11673	∅21,5 x 3	-	5
11674	M8 x 1,25	12 x 36,6	5
11675	M10 x 1,5	15,5 x 27,3	5
11676	M8 x 1,25	14,3 x 20	5
11677	M10 x 1,25	15,9 x 38	5
11678	M8 x 1,25	12 x 31,6	5
11679	M10 x 1	20,6 x 22	5
<b>Total</b>			<b>60</b>



## Ref. 0009



Clips for Brake Hoses

Ref.	d	Pcs.
3200	-	4
3201	-	4
3202	-	6
3203	-	4
3205	-	4
3206	-	4
3207	-	4
3208	-	4
3209	-	4
3210	-	4
3212	-	6
3213	-	4
3214	-	2
3216	-	2
3219	-	4
3220	-	4
3211	∅10,2 x 1	10
3218	∅12,3 x 0,8	4
<b>Total</b>		<b>78</b>

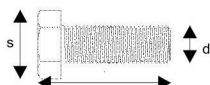

# Workshop Kit

Ref. 0009A 

Banjo Bolts for Brake Hoses

Ref.	d	s x tl	Pcs.
3250	M12 x 1	17 x 24	4
3251	M10 x 1	14 x 27,1	4
3252	M10 x 1,5	11 x 28,1	4
3253	M12 x 1	13 x 28,9	4
3254	M10 x 1	16 x 32,3	4
3255	M12 x 1	17 x 28	4
3256	M10 x 1	12 x 31,4	4
3257	M10 x 1,5	12 x 30,5	4
3258	M10 x 1	11 x 37	4
3259	M10 x 1	13 x 27,2	4
3260	M10 x 1,5	11 x 28,1	4
3261	M10 x 1	14 x 32,2	4
3262	M10 x 1	12 x 29,2	4
3263	M10 x 1	13 x 25,6	4
3211	∅10,2 x 1		6
3218	∅12,3 x 0,8		6
3225	∅10 x 1,5		6
3226	∅12 x 1,5		6
<b>Total</b>			<b>80</b>

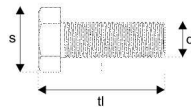

## Brake Hoses



In order to secure a safe braking, the Brake Hoses play an important part and should be inspected during every brake check

We carry a complete range which covers all European and Asian cars. Our program also includes the clips to mount and secure the hoses.

Please contact your local wholesaler for further information.

All application data can be found in TecDoc



(1:1)



# Brake Line Fittings, Clips & Connectors

d1 d2 s x tl

d1 d2 s x tl

A

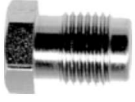

M10 x 1 ø5,2 11 x 16,7

Alfa Romeo, Audi, BMW, Chevrolet, Citroën, Dacia, Fiat, Ford, Honda, Hyundai, Kia, Mitsubishi, Mercedes, Nissan, Opel, Peugeot, Renault, Rover, Saab, Seat, Skoda, Suzuki, Toyota, Volvo, VW

Available in stainless steel (Ref: A-A2)

E



M10 x 1 ø5,2 14 x 14

Alfa Romeo, Audi, Citroën, Fiat, Ford, Opel, Peugeot, Renault, Rover, Seat, Saab, Volvo, VW

B

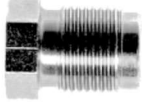

M12 x 1 ø6,2 12 x 18

Audi, Ford, Peugeot, Saab, Seat, Volvo, VW

EB

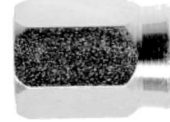

M12 x 1 ø5,2 15 x 21,5

Citroën, Ford, Peugeot, Seat, VW

B5.0

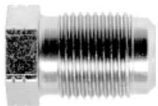

M12 x 1 ø5,2 12 x 20

Alfa Romeo, Audi, BMW, Citroën, Chevrolet, Daewoo, Fiat, Ford, Honda, Mazda, Nissan, Opel, Peugeot, Renault, Seat, Skoda, Saab, Suzuki, Volvo, VW

EV

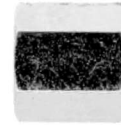

M10 x 1 ø5,2 14 x 15

Opel, Volvo

B5L

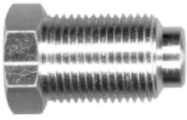

M12 x 1 ø5,2 13 x 24

Alfa Romeo, Citroën, Fiat, Mazda, Peugeot

F

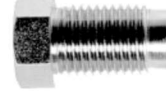

3/8" x 24UNF ø5,2 11 x 21

Renault, Saab, Vauxhall, Volvo

BX

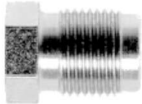

M12 x 1 ø6,5 12 x 18

G

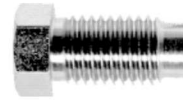

3/8" x 20UNF ø5,2 11 x 22,4

Rover

C



M10 x 1 ø5,2 11 x 24,8

Hyundai

H

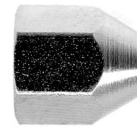

3/8" x 24UNF ø5,2 14 x 17,5

Bedford, Rover, Saab, Talbot, Vauxhall, Volvo

CI 0216X



M8 x 1,25 ø3,8 8 x 19,5

Citroën

HA

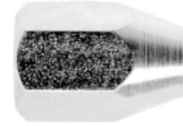

M10 x 1 ø5 15 x 23

Alfa Romeo, Citroën, Fiat, Mazda, Mercedes, Nissan, Opel, Seat

CI 0217



M9 x 1,25 ø4,8 9 x 20,8

Citroën

J



3/8" x 24UNF ø5,2 10 x 14,4

Volvo and US cars

D

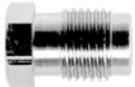

M10 x 1 ø5,2 10 x 16,7

Chevrolet, Daihatsu, Daewoo, Hyundai, Kia, Nissan, Opel, Skoda, Toyota, Vauxhall, VW

KX



3/8" x 24UNF ø5,2 12 x 16

Volvo

DL



M10 x 1 ø5,2 10 x 23

Honda, Kia, Suzuki, Toyota, Volvo, VW

L







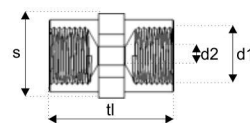
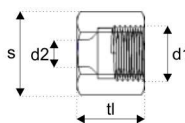
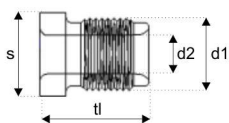



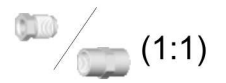

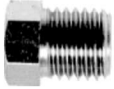
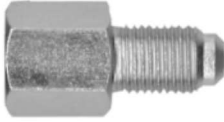
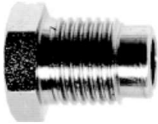
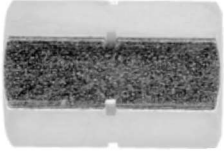
M10 x 1,25 ø5,2 10 x 19,5

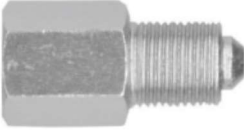
Autobianchi, Dacia, Fiat, Lada, Lancia, Zastava

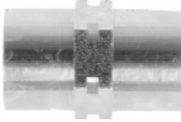
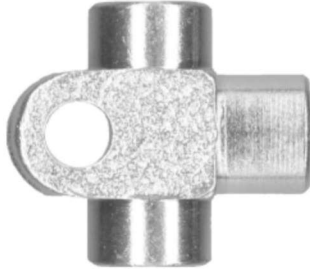

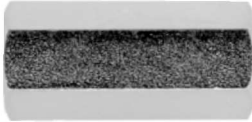
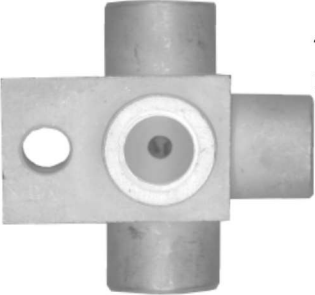
# Brake Line Fittings, Clips & Connectors

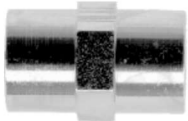

		d1	d2	s x tl		d1	d2	s x tl
M		M10 x 1,25	ø5,2	10 x 14,2				
		Mazda			OAE		2 x M10 x 1	ø3,2 14 x 29
							Connector	For single/double flaring.
N		M12 x 1,25	ø6,6	14 x 19,4	OBB		2 x M12 x 1	ø4,5 17 x 29
		Eastern European + Fiat 238					For double flaring.	
N5.0		M12 x 1,25	ø5,2	13 x 19,5	OBE		2 x M12 x 1	ø3,2 15 x 32
		Iveco					Connector	For single/double flaring.
O3A		3 x M10 x 1	ø3		ODD		2 x M10 x 1	ø3,5 14 x 24
		For single flaring.					For double flaring.	
O3B		3 x M12 x 1	ø3,5		OEE		2 x M10 x 1	ø3,2 11 x 28
		For double flaring.					For double flaring.	
O3D		3 x M10 x 1	ø4		OFF		2 x 3/8" x 24UNF	ø3,1 14 x 33,2
		For double flaring.					For single flaring.	
O4A		4 x M10 x 1	ø3		OKK		2 x 3/8" x 24UNF	ø3,2 11 x 28
		For single flaring.					For double flaring	
OAA		2 x M10 x 1	ø3,5	14 x 24	P		7/16" x 24UNF	ø5,2 12 x 23
		For single flaring.					Peugeot	

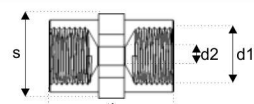
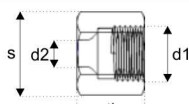
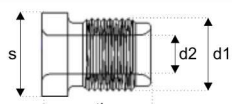



# Brake Line Fittings, Clips & Connectors



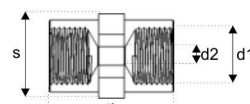
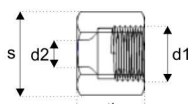
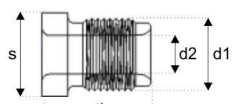





		d1	d2	s x tl		d1	d2	s x tl
P6.5		7/16" x 24UNF	ø6,5	12 x 23				
		Peugeot with 1/4" lines						
PA		7/16" x 24UNF	ø6,5	12 x 15,5				
		British and US cars with 1/4" lines						
PA5.0		7/16" x 24UNF	ø5,2	11 x 21				
		British and US cars with 1/4" lines						
PE		1/2" x 20UNF	ø8,2	13 x 15,8				
		Peugeot						
PF		1/2" x 20UNF	ø5,2	13 x 18				
		Peugeot						
PF6.0		1/2" x 20UNF	ø6,2	13 x 17				
PG		7/16" x 20UNF	ø5,2	12 x 21,5				
		Renault, Rover, Talbot						
PH		7/16" x 20UNF	ø6,5	14 x 24				
		Bedford with 1/4" lines						
PX		7/16" x 20UNF	ø6,6	12 x 23				
		Peugeot						
S		3/8" x 24UNF	ø5,2	10 x 18				
		Peugeot, Talbot, Volvo						
STT								
		Connector for 3/16" lines Assembles without flarings For Cu, CuNi and Steel Brake Lines						
STT5.0								
		Connector for 5 mm lines Assembles without flarings For Cu, CuNi and Steel Brake Lines						
STT6.0								
		Connector for 6 mm lines Assembles without flarings For Cu, CuNi and Steel Brake Lines						
STT8.0								
		Connector for 8 mm tubes Assembles without flarings For Cu, CuNi and Steel Brake Lines						
T		M10 x 1	ø5,2	10 x 18				
TX		M10 x 1	ø5,2	10 x 18				
		Chevrolet, Daewoo, Daihatsu, Honda, Hyundai, Isuzu, Mazda, Mitsubishi, Nissan, Opel, Suzuki, Toyota, VW						
TXL		M10 x 1	ø5,2	10 x 24				
		Kia, Nissan, Suzuki, Toyota						
W								
		For fastening two 3/16" or 5 mm lines						
WA								
		For fastening two 3/16" or 5 mm lines Use 8 mm drill						
WB								
		For fastening three 3/16" or 5 mm lines Use 7 mm drill						

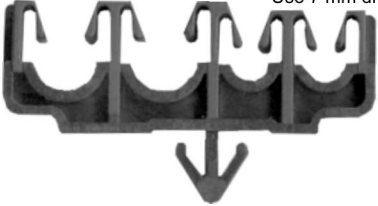
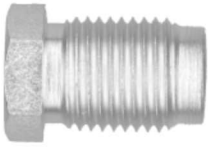

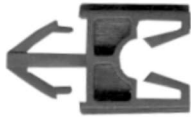

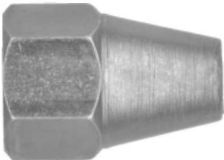
# Brake Line Fittings, Clips & Connectors (1:1)

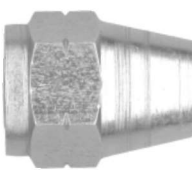

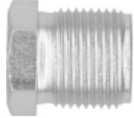
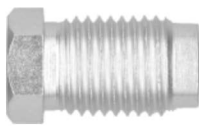

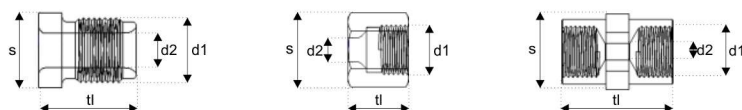















	d1	d2	s x tl		d1	d2	s x tl	
WD				For fastening two 3/16" or 5 mm, and two 5/16" or 8 mm lines Use 7 mm drill 	ZC			M16 x 1,5    ø10,6    17 x 26,5 Audi, BMW, MAN, Mercedes, VW 
X				For fastening one 3/16" or 5 mm line Use 6 mm drill 	ZD			5/8" x 18UNF    ø10,2    17 x 16,5 
XA				For fastening one 3/16" or 5 mm line Use 7 mm drill 	ZE			M14 x 1,5    ø8,5    14 x 25 Audi, BMW, MAN, Mercedes, VW For double flaring. 
XB				For fastening one 1/4" or 6 mm line Use 7 mm drill 	ZF			M14 x 1,5    ø8,4    19 x 29 
XC				For fastening one 5/16" or 8 mm line Use 7 mm drill 	ZG			M16 x 1,5    ø10,3    19 x 25,5 
Z				M14 x 1    ø8,2    14 x 16,5 Audi, BMW, MAN, Mercedes, VW For single flaring 				
ZA				M14 x 1    ø8,2    14 x 16,5 Audi, BMW, MAN, Mercedes, VW For double flaring. 				
ZB				M14 x 1,5    ø8,2    14 x 25,5 Audi, BMW, MAN, Mercedes, VW For single flaring. 				



(1:1)



# Bleeder Screws



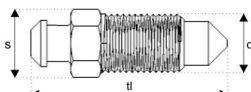









	d1	s x tl		d1	s x tl	
0010	M8 x 1,25	9 x 41,5	 <p>Citroën, Fiat, Lancia, Mercedes, Opel, Peugeot, Seat, Skoda, Smart, Vauxhall, Volvo, VW</p>	0033	M6 x 1 7 x 29	 <p>Audi, BMW, Fiat, Mercedes, Opel, Saab, Seat, VW</p>
0011	M8 x 1,25	9 x 35,5	 <p>Chevrolet, Chrysler, Citroën, Daewoo, Ford, Honda, Mercedes, Mini, Opel, Renault, Saab, Skoda, Suzuki, Vauxhall, Volvo</p>	0039	M10 x 1 11 x 29,9	 <p>Alfa Romeo, Audi, Austin, BMW, Chevrolet, Chrysler, Citroën, Daewoo, Daihatsu, Dodge, Fiat, Ford, Honda, Hyundai, Iveco, Jaguar, Kia, Land Rover, Mazda, Mercedes, Mitsubishi, Nissan, Opel, Peugeot, Renault, Rover, Saab, Seat, Skoda, Ssangyong, Subaru, Suzuki, Toyota, Vauxhall, Volvo, VW</p> <p><b>Available in stainless steel (Ref: 0039-A2)</b></p>
0013	M6 x 1	7 x 38	 <p>Audi, Seat, Skoda, Subaru, VW</p>	0040	M12 x 1 13 x 31,4	 <p>Ford</p>
0015	M8 x 1,25	9 x 32,5	 <p>Alfa Romeo, Audi, BMW, Chevrolet, Citroën, Fiat, Ford, Honda, Land Rover, Mazda, Mercedes, Mini, Nissan, Opel, Peugeot, Renault, Saab, Seat, Skoda, Toyota, Vauxhall, Volvo, VW</p>	0053	M7 x 1 7 x 22,2	 <p>Alfa Romeo, BMW, Citroën, Dacia, Daihatsu, Fiat, Ford, Hyundai, Isuzu, Mazda, Mitsubishi, Nissan, Opel, Peugeot, Renault, Rover, Seat, Skoda, Smart, Talbot, Vauxhall, Volvo, VW</p>
0016	M10 x 1	10 x 32	 <p>Chevrolet, Hyundai, Kia</p>	0053X	M7 x 1 7 x 26,2	 <p>Citroën, Fiat, Ford, Mercedes, Nissan, Opel, Peugeot, Renault, Smart, Suzuki, Volvo</p>
0017	M10 x 1	10 x 34	 <p>Alfa Romeo, Audi, BMW, Chevrolet, Daewoo, Daihatsu, Ford, Honda, Hyundai, Isuzu, Kia, Lancia, Mazda, Mini, Mitsubishi, Nissan, Opel, Peugeot, Renault, Rover, Skoda, Subaru, Suzuki, Toyota, Vanden Plas, Vauxhall, Volvo, VW</p>	0069	M7 x 1 7 x 28,6	 <p>Alfa Romeo, Citroën, Fiat, Ford, Isuzu, Lancia, Mazda, Mitsubishi, Nissan, Peugeot, Renault, Rover, Seat, Skoda, Suzuki, Talbot, Toyota, Volvo</p>
0018	M10 x 1	10 x 36,5	 <p>Daihatsu, Ford, Iveco, Rover, Talbot (Simca), Toyota, Triumph</p>	0085	M8 x 1,25 9 x 49,5	 <p>Ford, Mercedes</p>
0019	M10 x 1	11 x 36	 <p>Alfa Romeo, Audi, BMW, Chevrolet, Citroën, Daewoo, Fiat, Ford, Honda, Hyundai, Kia, Lancia, Land Rover, Mazda, Mercedes, MG, Mitsubishi, Nissan, Opel, Peugeot, Seat, Skoda, Ssangyong, Subaru, Suzuki, Toyota, Volvo, VW</p>	0086	M7 x 1 7 x 30,5	 <p>Alfa Romeo, Audi, BMW, Citroën, Daihatsu, DAF, Fiat, Ford, Honda, Jaguar, Lancia, Land Rover, Mazda, Mercedes, Mitsubishi, Nissan, Opel, Peugeot, Renault, Rover, Saab, Seat, Subaru, Suzuki, Talbot, Toyota, Volvo, VW</p>
0020	M10 x 1	11 x 41,8	 <p>Mercedes</p> <p><b>With rubber seal</b></p>	0087	M7 x 1 7 x 38,3	 <p>Alfa Romeo, Audi, BMW, Citroën, Daihatsu, Ford, Mazda, Opel, Peugeot, Renault, Saab, Seat, Skoda, Subaru, Talbot, Toyota, Vauxhall, Volvo, VW</p>



# Bleeder Screws



(1:1)

	d1	s x tl		d1	s x tl
0088	M7 x 1	9 x 33		0103	M10 x 1,5 10 x 29,5
	Citroën, Daihatsu, Fiat, Mazda, Mercedes, Mitsubishi, Nissan, Opel, Peugeot, Renault, Saab, Subaru, Suzuki, Toyota, Vauxhall				Cadillac, Chevrolet, Chrysler, Ford, Opel, Pontiac
0089	M8 x 1	8 x 32		0105	1/4" x 28UNF 7 x 28,5
	Ford, Kia, Mazda				Rover, Vauxhall
0090	M8 x 1	9 x 33,5		0107	3/8" x 24UNF 10 x 30,5
	Kia, Mazda, Mercedes, Mitsubishi, Opel, Saab, Suzuki, Toyota, Vauxhall				Chrysler, Ford, Hyundai, MG, Mitsubishi, Nissan, Rover, Sunbeam, Suzuki, Talbot, Vauxhall, Volvo
0091	M8 x 1	8 x 38		0108	3/8" x 24UNF 10 x 36,7
	Mazda				Jaguar, Lotus, Morgan, Rover, Saab, Sunbeam, Talbot, Triumph, Vauxhall
0092	M8 x 1,25	8 x 34,7		0120X	1/4" x 28UNF 8 x 28
					Iveco, Rover, Volvo
0093	M8 x 1,0	8 x 28,3		0122	5/16" x 24UNF 8 x 25,5
	Hyundai, Kia, Mazda, Mitsubishi, Suzuki				Hyundai, Kia
0094	M7 x 1	8 x 55,5		0123	M10 x 1,5 10 x 37,6
	Ford, Mitsubishi				Chrysler
0100	M8 x 1,25	8 x 24,5		0125	Dust Cap All Bleeder Screws
	Alfa Romeo, Autobianchi, Citroën, Daewoo, Fiat, Ford, Honda, Jaguar, Kia, Lada, Lancia, Mazda, Mercedes, Mitsubishi, Nissan, Opel, Peugeot, Polmo, Renault, Rover, Saab, Seat, Talbot, Toyota, Vanden-Plas, Vauxhall, Wartburg, Zastava				
0101	M10 x 1,25	10 x 28		0126	Dust Cap All Bleeder Screws
	Honda, Rover				
0102	M10 x 1,25	10 x 33			
	Honda, Rover				

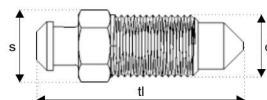



(1:1)



# Brake Hose Clips & Washers

3200

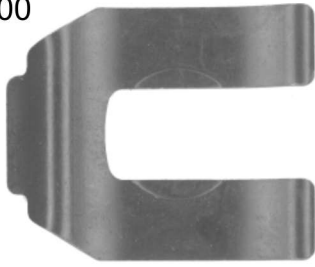

Fiat, Mercedes, Opel, Renault, Skoda, Vauxhall, VW

3208



Alfa Romeo, Daihatsu, Ford, Hyundai, Kia, Mazda, Mitsubishi, Nissan, Suzuki, Volvo

3201



Alfa Romeo, Autobianchi, Citroën, Fiat, Ford, Kia, Lada, Lancia, Land Rover, Opel

3209

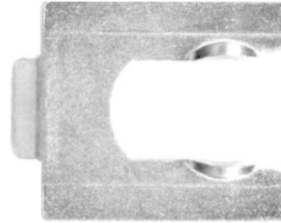

Citroën, Fiat, Lancia, Peugeot, Renault, Peugeot, Saab, Seat, Smart, Vauxhall, VW, Zastava

3202



Alfa Romeo, Audi, BMW, Citroën, Dacia, Mercedes, Mini, Nissan, Opel, Peugeot, Renault, Seat, Talbot, Toyota, Vauxhall, VW

3210

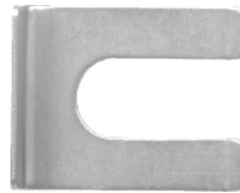

Daihatsu, Lexus, Toyota, VW

3203



Daihatsu, Mercedes, Subaru, Toyota

3211



ø10,2 x 1  
Copper  
UNIVERSAL

3205

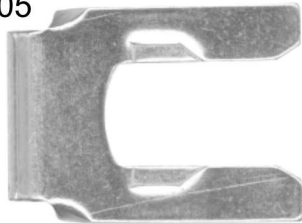

Alfa Romeo, Citroën, Fiat, Kia, Lancia, Mazda, Mercedes, Peugeot, Talbot

3212



Alfa Romeo, Audi, Citroën, Dacia, Land Rover, Mercedes, Mitsubishi, Nissan, Opel, Peugeot, Porsche, Renault, Rover, Seat, Skoda, Saab, Toyota, Vauxhall, Volvo, VW

3206

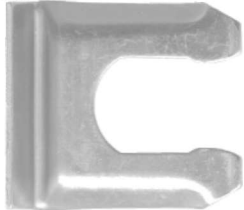

Bedford, Chevrolet, Daewoo, Ford, Isuzu, Opel, Rover, Saab, Suzuki, Vauxhall

3213



Ford, Jaguar, Kia, Mazda

3207



Audi, BMW, Fiat, Honda, Lancia, Land Rover, Mazda, MG, Rover, Seat, Skoda, VW











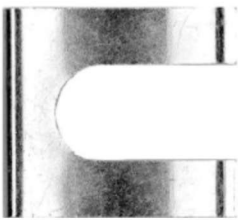

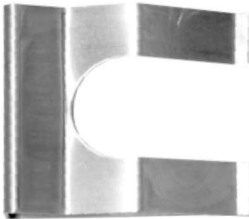
3214

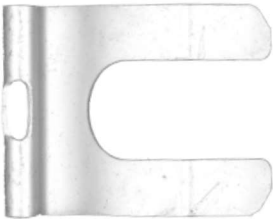

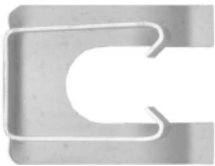
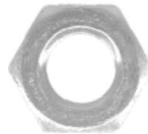
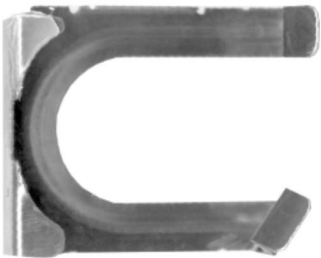
Ford

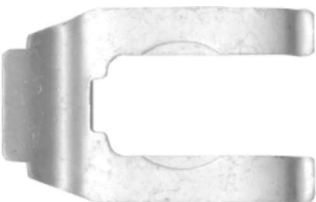
# Brake Hose Clips & Washers

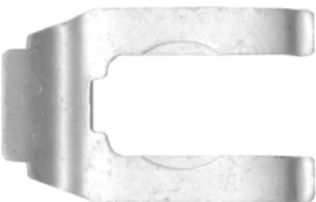

<p>3216</p>  <p>Citroën, Daihatsu, Honda, Lexus, Peugeot, Toyota</p>	<p>3223</p>  <p>Mercedes</p>
<p>3217</p>  <p>Hyundai, Kia, Mitsubishi, Opel, Smart, Subaru, Suzuki, Vauxhall</p>	<p>3224</p>  <p>Renault</p>
<p>3218</p>  <p>ø12,3 x 0,8 Copper UNIVERSAL</p>	<p>3225</p>  <p>ø10 x 1,5 Aluminium UNIVERSAL</p>
<p>3219</p>  <p>Ford, Hyundai, Kia, Mazda</p>	<p>3226</p>  <p>ø12 x 1,5 Aluminium UNIVERSAL</p>
<p>3220</p>  <p>Subaru</p>	<p>3231</p>  <p>M10 x 1      17 x 8 Volvo 240</p>
<p>3221</p>  <p>BMW</p>	<p>3232</p>  <p>3/8" x 24UNF      14 x 5,5</p>
<p>3222</p>  <p>BMW</p>	<p>3290</p>  <p>Plastic clamp</p>
<p>3222</p>  <p>BMW</p>	<p>3291</p>  <p>Plastic support clip</p>

(1:1)



# Brake Hose Banjo Bolts

	d	s x tl		d	s x tl
3250	M12 x 1	17 x 24		3258	M10 x 1 Opel 11 x 37
3251	M10 x 1 Honda, Mitsubishi, Toyota	14 x 27,1		3259	M10 x 1 Mitsubishi 13 x 27,2
3252	M10 x 1,5 Opel	11 x 28,1		3260	M10 x 1,5 VAG 11 x 28,1
3253	M12 x 1 Saab	13 x 28,9		3261	M10 x 1 Fiat, Honda, Mazda, Opel, Suzuki, Toyota 14 x 32,2
3254	M10 x 1 Ford	16 x 32,3		3262	M10 x 1 Kia, Mitsubishi 12 x 29,2
3255	M12 x 1	17 x 28		3263	M10 x 1 Peugeot 13 x 25,6
3256	M10 x 1 Hyundai, Kia, Nissan	12 x 31,4			
3257	M10 x 1,5 Chevrolet, Opel	12 x 30,5			

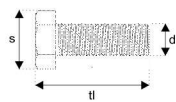



# Nuts, stub axle



(1:1)

d s x tl

d s x tl

9802

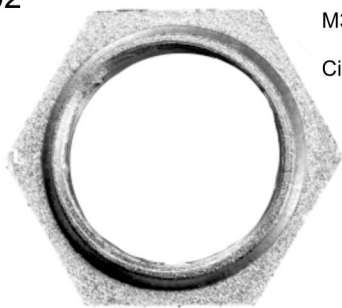

M30 x 1,5 40 x 16,5  
Citroën, Peugeot

9811

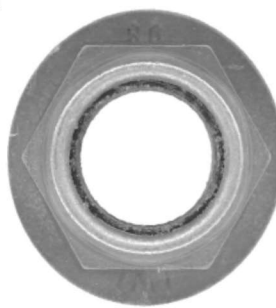

M20 x 1,5 30 x 20  
Renault

9803



M28 x 1,5 36 x 19  
Citroën, Fiat

9812

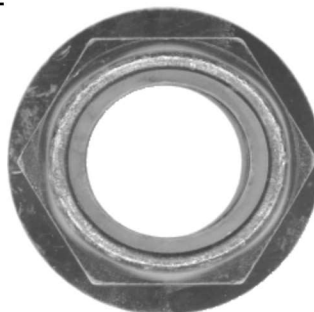

M24 x 2 36 x 23,7  
Ford

9804



M22 x 1,5 32 x 16,6  
Citroën, Fiat

9813



M20 x 1,5 30 x 17,5  
Ford, Mazda

9805



M18 x 1,5 26 x 16,5  
Citroën, Peugeot

9806



M20 x 1,5 30 x 14,7  
VW

(1:1)



# Grease Caps, stub axle

TOP

SIDE

9821



Fits hole  $\varnothing 59$



$\varnothing 62 \times 27$

9822

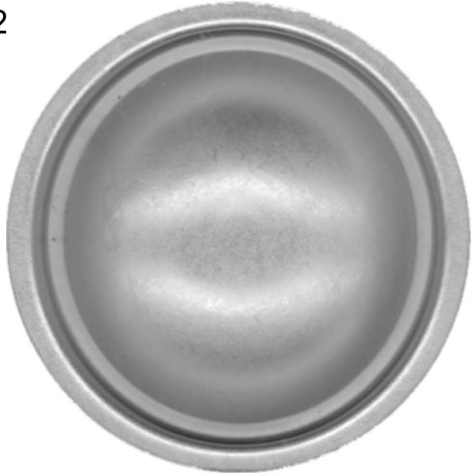

Fits hole  $\varnothing 56$



$\varnothing 62,4 \times 12$

9823



Fits hole  $\varnothing 56$



$\varnothing 56,4 \times 26,5$

9824



Fits hole  $\varnothing 40$



$\varnothing 53,1 \times 15,2$

# Grease Caps, stub axle



(1:1)

TOP

SIDE

9825



ø72,8 x 28

Fits hole ø70

9826



ø64,1 x 11,2

Fits hole ø60

9827



ø66 x 22

Fits hole ø58

(1:1)



# Grease Caps, stub axle

TOP

SIDE

9828

ø59,2 x 16,4



Fits hole ø53

9829

ø54,5 x 21,5



Fits hole ø54

9841











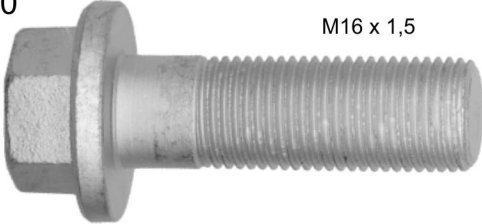

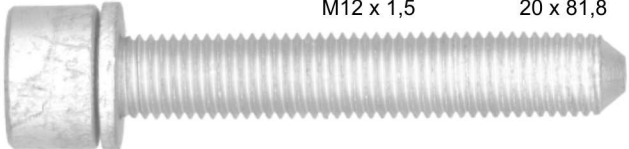
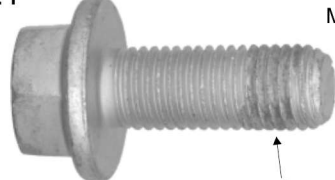
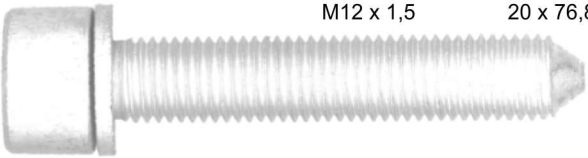
ø21 x 0,8

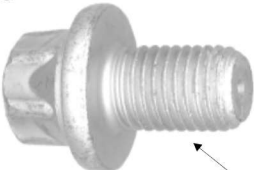

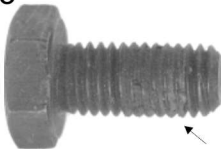
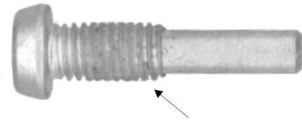

# Fixing Screws for Disc and Drum Brakes (1:1)





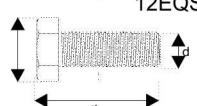





	d1	s x tl	d1	s x tl
11610	M16 x 1,5	21 x 61,6	M12 x 1,5	19 x 53
				With lock fluid
11611	M12 x 1,5	20 x 81,8	M12 x 1,5	18 x 41,4
				With lock fluid
11612	M12 x 1,5	20 x 76,8	M6 x 1	11,7 x 19,9
				Hexagon 4
11613	M12 x 1,5	23,4 x 32	M6 x 1	12 x 13
				Torx 30
11615	M10 x 1,5	17 x 28,4	M8 x 1,25	13 x 37,8
				Torx 40
11616	M12 x 1,5	19 x 37	M12 x 1,5	19 x 42,5
				
11617	M6 x 1	9,8 x 15,8	M8 x 1,25	13 x 23,2
				
11618	M6 x 1	10,8 x 14	M14 x 1,5	29,6 x 53,6
				

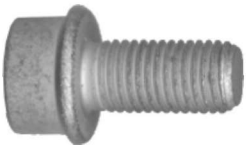
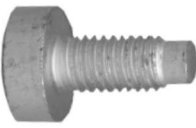

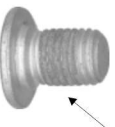
(1:1)



# Fixing Screws for Disc and Drum Brakes

		d1	s x tl		d1	s x tl
11631		M10 x 1,25	18,8 x 30	11666	M10 x 1,25	13,3 x 19,4
Hexagon 8				Hexagon 5		
11632		M8 x 1,25	16 x 25	11667	M6 x 1	11 x 16,1
				Torx 30		
11660		M6 x 1	14 x 15	11668	M8 x 1,25	10,9 x 15,6
Hexagon 5	With lock fluid			Hexagon 5		
11661		M8 x 1	14 x 12,5	11669	M10 x 1,5	10 x 18,9
Torx 30	With lock fluid			Torx 50		
11662		M8 x 1,25	15,9 x 15,7	11670	M10 x 1,5	18 x 19,7
Hexagon 6				Torx 50		
11663		M8 x 1,25	15,5 x 17	11671	M6 x 1	11 x 14
Torx 40				Torx 30		
11664		M12 x 1,5	18,8 x 21,3	11672	M8 x 1,25	11,8 x 17,8
Torx 50				Torx 30		
11665		M8 x 1,25	15,8 x 16,1	11673	ø21,5 x 3	
Hexagon 5						

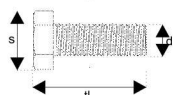

# Fixing Screws for Disc and Drum Brakes

(1:1)



	d1	s x tl		d1	s x tl
11674	M8 x 1,25	12 x 36,6		11678	M8 x 1,25 12 x 31,6
11675	M10 x 1,50	15,5 x 27,3	Hexagon 6 	11679	M10 x 1 20,6 x 22
11676	M8 x 1,25	14,3 x 20	PH 3 	11558X	M10 x 1,5 13 x 38,6
11677	M10 x 1,25	15,9 x 38		4904	M6 x 1 10 x 16

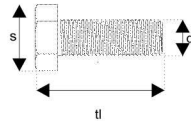

## Glide Piece - backplate

(1:1)



6858K

Audi, Seat, Skoda, VW



Axle kit with 12 pcs

6859K

Skoda, VW



Axle kit with 12 pcs





## **QUICK** Repair system

- Which parts are most often forgotten or not replaced when changing Brake Shoes or Brake Pads?
- Do you know that the spring force will reduce with 50% to 70% within 1-2 years?

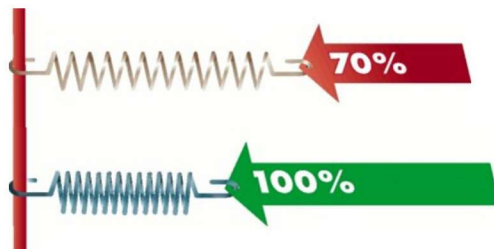

When repairing the brakes, for technical and safety reasons, it is recommended also to change the Accessory Kit. This to ensure even braking ability and functionality.

**Safety comes first**



# QUICK Repair System for Drum Brakes

**Accessory Kit for Brake Shoes**  
(105-XXXX) - Axle kit



**Self Adjuster Kit for Brake Shoes**  
(102 53 XXX) - Axle kit



**Expander Lock Kit for Hand Brake Shoes**  
(120 53 XXX) - Axle kit

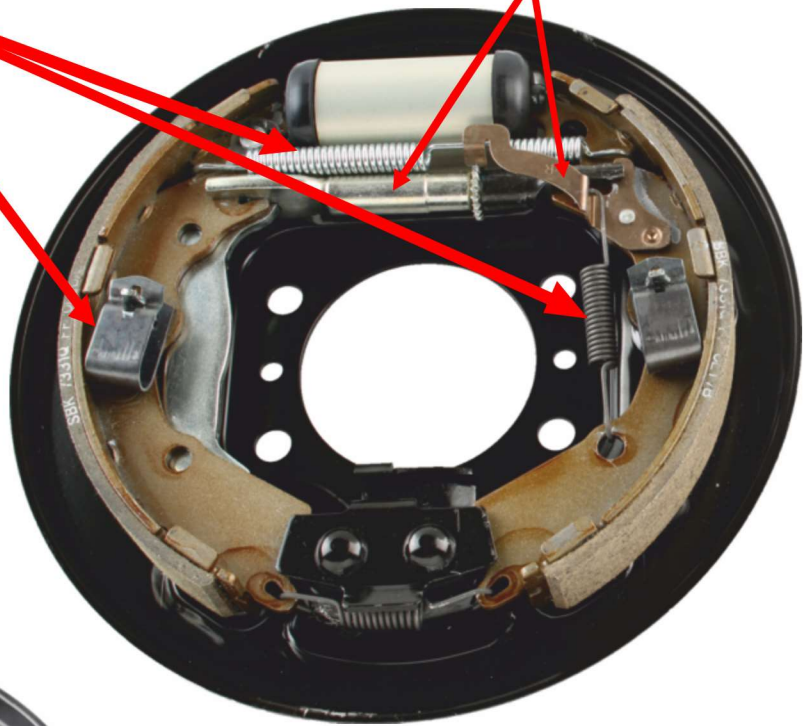

When changing the Brake Shoes, for technical and safety reasons, it is recommended also to change the Accessory Kit, the Brake Adjuster Kit or the Expander Lock Kit. This to ensure even braking ability and functionality.

# QUICK Repair System for Disc Brakes

**Brake Caliper Piston Seal Kit**  
(114-XXXX) - **Wheel kit**



**Guide Sleeve Kit**  
(113-XXXX) - **Wheel kit**

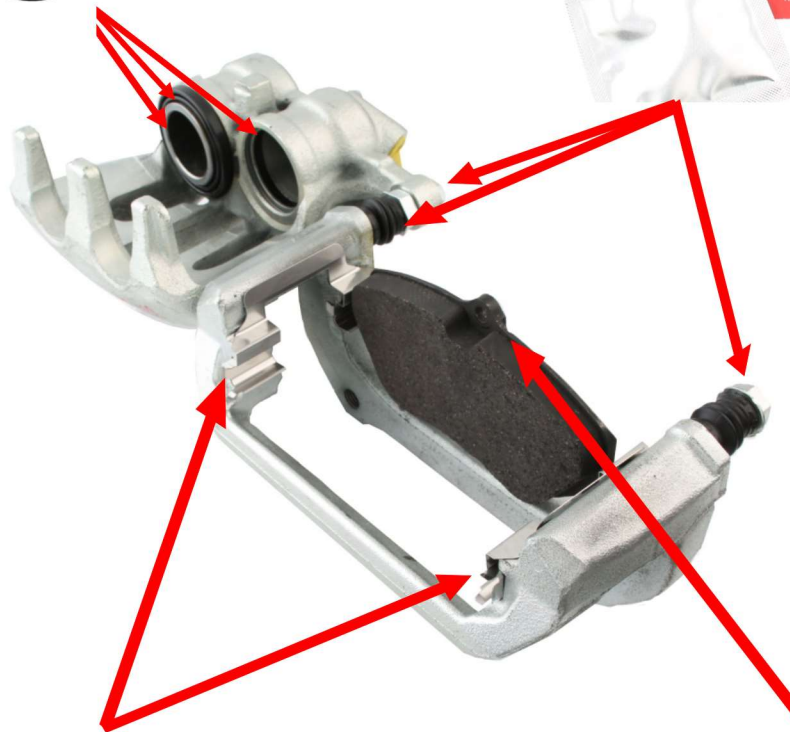

**Accessory Kit for Brake Pads**  
(109-XXXX) - **Axle kit**



**Brake Wear Sensor Kit**  
(WS XXXX A) - **Axle kit**



When repairing the Caliper, for technical and safety reasons, it is recommended also to change the Brake Caliper Piston Seal Kit, the Guide Sleeve Kit, the Accessory Kit for the Brake Pads and the Wear Sensor Kit. This to ensure even braking ability, function and **increase safety when braking!**



# QUICK Brake Wear Sensors

## OJD Range:

- OJD range covers 95% of the European car park.
- Often used on brands like Audi, BMW, Jaguar, Land Rover, Mercedes and others.
- OJD range is constantly being updated to ensure that we meet the market demands for both existing and new cars.



## Quality:

- Our wear sensors are made from high quality materials to ensure best possible product.
- Can withstand high radiant heat exposure and cold temperatures.
- Packed in polybags with zip lock. Easy to store in warehouse or local stores.



## Why change the Wear Sensors?

- Once a Brake Wear Sensor has been activated, it has to be replaced with a new one.
- If the Wear sensors is not changed, the warning light will continue to show.
- It is recommended to change the wear sensor when changing brake pads.









# **QUICK BRAKE®**

OJD Automotive ApS  
Lerbaekvej 16  
DK - 2680 Solroed Strand  
Tlf: (+45) 56 14 14 28  
Fax: (+45) 56 14 68 06  
E-mail: [ojd@ojd.dk](mailto:ojd@ojd.dk)  
[www.ojd.dk](http://www.ojd.dk)